

SPECIFICATIONS

Size	Metric	British
Max. Working Height A	5.70m	18ft 8in
Max. Platform Height B	3.70m	12ft 2in
Overall Length C	1.56m	5ft 1in
Overall Width D	1.06m	3ft 6in
Overall Height E	2.42m	
Platform Size(Length×Width)	0.71m×0.80m	2ft 4in×2ft 8in
Ground Clearance	0.08m	3in
Wheelbase	1.27m	4ft 2in
Turning Radius	0	0
Tyres(Drive Motors)	Φ230×80mm	Φ9in×3in
Tyres(Front)	0.15m	6in

Performance		
S.W.L	300kg	661lb
Max. Occupants	1	1
Travel Speed(Stowed)	4.0km/h	2.5mph
Travel Speed(Raised)	0.8km/h	1.5mph
UP/Down Speed	22/19sec	22/19sec
Gradeability	25%	25%
Max. Working Slope	X-1.5°/Y-2°	X-1.5°/Y-2°

Weight		
Weight	720kg	1587lb

Power		
Battery	2×12V/105Ah	2×12V/105Ah
Charger	24V/30A	24V/30A
Drive Motor	2×24VDC/0.4kW	2×24VDC/0.4kW
Lifting Motor	24V/2.2kW	24V/2.2kW

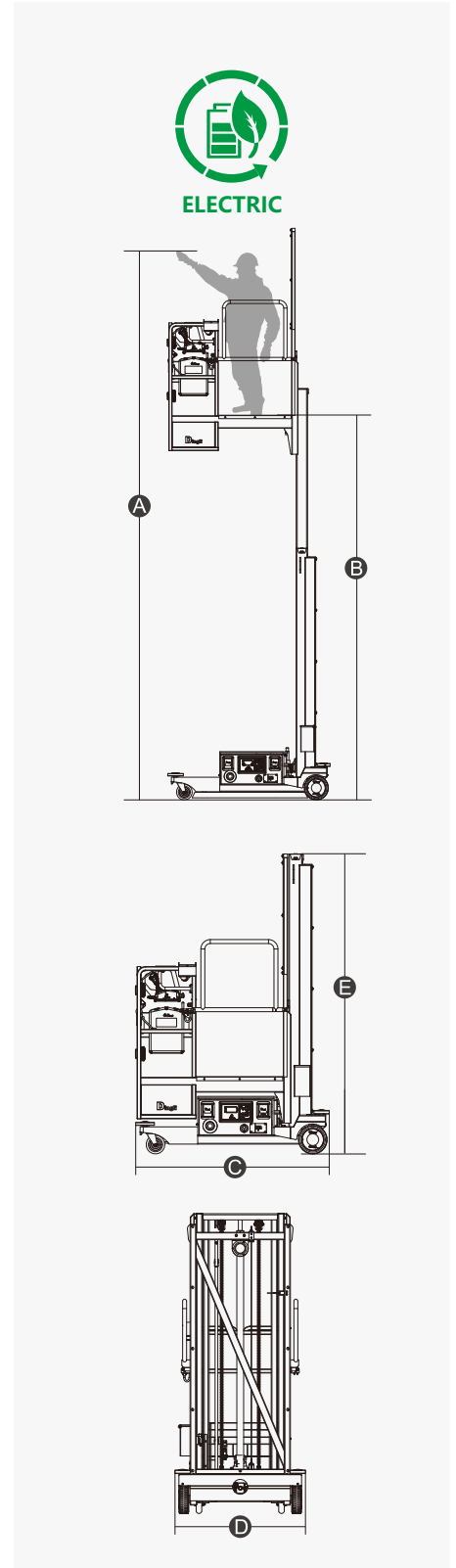

FEATURES

Standard Items

- Proportional Joystick Controls
- Self-Locking Gates
- Drivable At Full Height
- Non-Marking Tires
- Two-Wheel Drive
- Two-Wheel Steering
- Automatic Braking System
- Emergency Descent System
- Tubing Explosion-Proof System
- Tilt Alarm
- Motion Alarm
- Horn
- Hour Meter
- Charging Indicator
- Charging Protection System
- Flashing Beacon
- Drive Enable
- Lanyard Attachment Point
- Tie-Down And Lifting Points
- Platform Load Sense System
- Emergency Stop Button
- Battery Indicator
- Safety Arm
- Anti-Collision Wheels



ZHEJIANG DINGLI MACHINERY CO., LTD.

Address: No.188 Qihang Road,Deqing,Zhejiang P.R.C 313219

Telephone: +86(572)8681688

E-Mail: export@cndingli.com

[Https://en.cndingli.com](https://en.cndingli.com)

Due to continuous technology updates, technical parameters are subject to change without notice. This picture book is for reference only, the actual product shall prevail. The copyright is owned by zhejiang dingli, any content may not be copied for any purpose without written permission.

2022-10

